

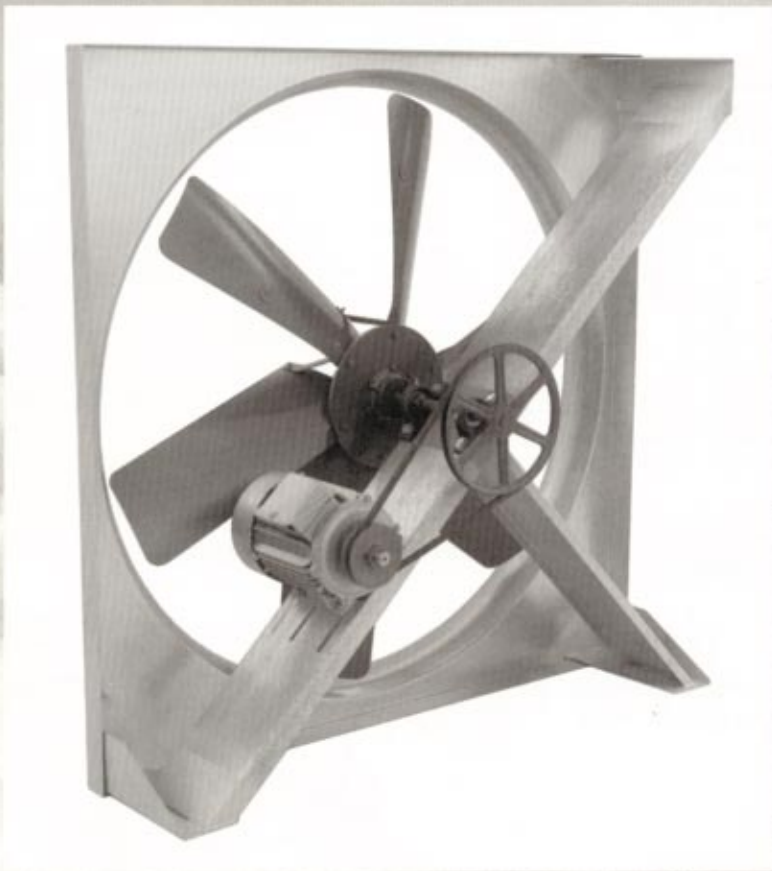

PROPELLER FANS

BELT DRIVE—EXHAUST AND SUPPLY



PEERLESS ELECTRIC

MADISON MANUFACTURING COMPANY

AFFILIATE OF PEERLESS-WINSMITH, INC.

PEERLESS ELECTRIC PERFORMANCE TABLE

MODELS PT & PTS BELT DRIVE

BLADE DIA.	MOTOR HP	RPM	SONES @ 5 FT.	CFM @ STATIC PRESSURE/BHP							SHIP WT.
				0.00 SP	1/20 SP (0.050)	1/10 SP (0.100)	1/8 SP (0.125)	1/4 SP (0.250)	3/8 SP (0.375)	1/2 SP (0.500)	
24	1/4	625	11.4	5,300 / 0.30	5,000 / 0.31	4,650 / 0.32	4,450 / 0.33	2,600 / 0.33	-	-	125
	1/3	680	13.9	5,800 / 0.39	5,500 / 0.40	5,200 / 0.41	5,050 / 0.42	3,250 / 0.42	-	-	130
	1/2	720	15.5	6,550 / 0.56	6,300 / 0.57	6,050 / 0.58	5,900 / 0.59	5,000 / 0.62	3,200 / 0.62	-	130
	3/4	870	23.0	7,400 / 0.81	7,200 / 0.83	6,950 / 0.84	6,850 / 0.85	6,200 / 0.89	4,800 / 0.89	3,500 / 0.92	135
	1	960	27.0	8,200 / 1.09	8,000 / 1.11	7,800 / 1.12	7,700 / 1.13	7,100 / 1.17	6,350 / 1.21	4,600 / 1.18	140
	1-1/2	1080	32.0	9,200 / 1.55	9,050 / 1.56	8,850 / 1.58	8,750 / 1.59	8,300 / 1.64	7,700 / 1.69	6,900 / 1.73	150
30	1/4	460	10.2	7,400 / 0.33	6,700 / 0.33	5,900 / 0.33	5,200 / 0.33	-	-	-	150
	1/3	493	11.6	7,900 / 0.41	7,300 / 0.41	6,600 / 0.41	6,100 / 0.41	-	-	-	155
	1/2	565	15.1	9,000 / 0.62	8,500 / 0.61	7,900 / 0.61	7,600 / 0.62	4,700 / 0.61	-	-	155
	3/4	635	18.9	10,200 / 0.88	9,700 / 0.88	9,200 / 0.87	8,900 / 0.87	7,000 / 0.88	4,300 / 0.87	-	160
	1	700	22.0	11,200 / 1.18	10,800 / 1.17	10,400 / 1.17	10,000 / 1.16	8,700 / 1.18	6,000 / 1.16	4,200 / 1.22	165
	1-1/2	795	29.0	12,700 / 1.74	12,300 / 1.73	12,000 / 1.72	11,800 / 1.71	10,700 / 1.72	9,000 / 1.73	6,500 / 1.70	175
36	1/3	400	11.4	10,100 / 0.42	9,100 / 0.42	7,900 / 0.43	7,100 / 0.43	-	-	-	180
	1/2	457	14.4	11,600 / 0.63	10,700 / 0.63	9,700 / 0.64	9,200 / 0.64	5,000 / 0.65	-	-	180
	3/4	505	17.6	12,800 / 0.85	12,000 / 0.85	11,200 / 0.86	10,700 / 0.86	7,000 / 0.86	-	-	185
	1	560	22.0	14,200 / 1.16	13,400 / 1.16	12,600 / 1.16	12,300 / 1.17	9,700 / 1.17	6,000 / 1.19	-	190
	1-1/2	633	26.0	16,100 / 1.67	15,500 / 1.67	14,900 / 1.67	14,400 / 1.25	12,500 / 1.69	9,300 / 1.68	6,400 / 1.74	200
	42	1/3	335	11.1	12,200 / 0.41	10,800 / 0.41	8,900 / 0.42	7,500 / 0.43	-	-	-
1/2		378	14.1	13,800 / 0.59	12,500 / 0.59	11,000 / 0.61	10,100 / 0.61	-	-	-	195
3/4		425	17.9	15,500 / 0.83	14,300 / 0.83	13,100 / 0.84	12,400 / 0.87	7,500 / 0.90	-	-	200
1		475	22.0	17,300 / 1.17	16,300 / 1.18	15,200 / 1.19	14,700 / 1.20	10,800 / 1.23	6,100 / 1.31	-	205
1-1/2		530	26.0	19,300 / 1.62	18,400 / 1.62	17,500 / 1.63	17,000 / 1.64	14,200 / 1.69	9,800 / 1.72	-	215
48		1/2	330	13.8	16,100 / 0.57	14,500 / 0.60	12,700 / 0.63	11,600 / 0.63	-	-	-
	3/4	370	17.4	18,100 / 0.80	16,700 / 0.84	15,100 / 0.88	14,200 / 0.89	-	-	-	230
	1	410	22.0	20,000 / 1.09	18,700 / 1.14	17,400 / 1.18	16,600 / 1.20	11,600 / 1.25	-	-	235
	1-1/2	460	26.0	22,500 / 1.54	21,300 / 1.59	20,100 / 1.63	19,500 / 1.66	15,900 / 1.71	10,300 / 1.80	-	245

PERFORMANCE RATINGS- The ratings shown are based on tests made in accordance with AMCA standard 210. Performance shown is for units without inlet or outlet ducts. BHP does not include drive losses.

Performance shown is for Types PT and PTS without ducts.
Loudness values in sones at a distance of five feet.

DIMENSIONS

MODEL PT BELT DRIVE EXHAUST FAN /
MODEL PTS BELT DRIVE SUPPLY FAN

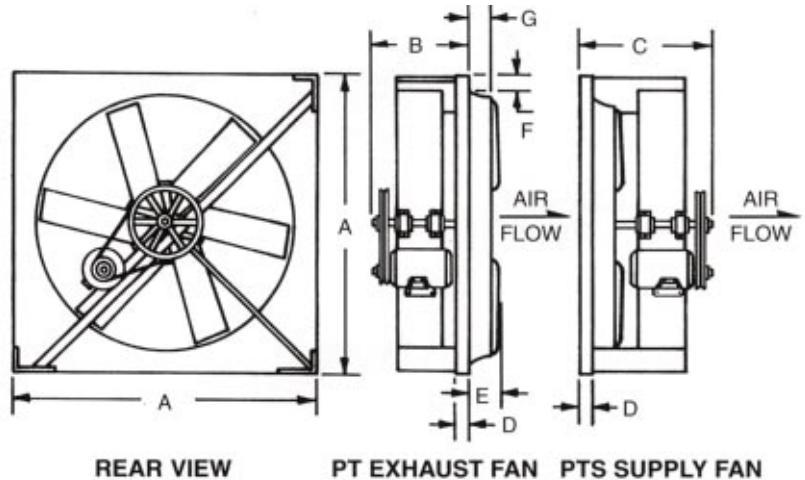

FAN SIZE	PANEL "A" SQ.	B	C	D	E	F	G	METAL GAUGE			AVG. SHIP WT.
								PANEL ¹	BLADES ²	SUPPORTS ¹	
24	30	15	21	2	5	2-1/8	3	16	16	12	90#
30	36	15	21	1-1/2	5	2-1/8	3	16	16	12	110#
36	42	15	21	1-7/8	5	2-1/8	4-1/2	16	16	12	130#
42	48	15	21	3	5	1-7/8	4-1/2	14	16	12	145#
48	54	15	21	2-3/4	6	1-1/16	4-1/2	14	16	12	165#

NOTES:

1. All steel construction with a baked on epoxy finish.
2. All G90 galvanized steel construction.
3. This unit good for 56 thru 145T motor frames only.

DIMENSIONS

ASSEMBLED WALL HOUSING

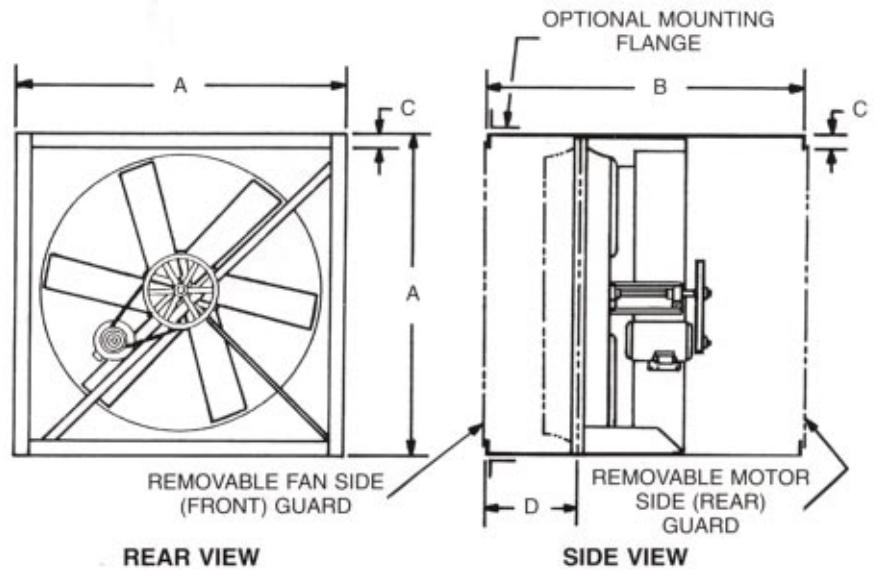

FAN ⁴ SIZE	HOUSING ¹ "A" SQ.	B	C	D	GAUGE ²	AVG. WT.	MOUNTING ³ FLANGE	FAN SIDE MOTOR SIDE GUARDS
24	30	26	2	8	18	52#	2 X 2 X 3/16 STL	2 X 2 MESH
30	36	26	2	8	18	60#	2 X 2 X 3/16 STL	2 X 2 MESH
36	42	26	2	8	18	69#	2 X 2 X 3/16 STL	2 X 2 MESH
42	48	26	2	8	18	77#	2 X 2 X 3/16 STL	2 X 2 MESH
48	54	26	2	8	18	85#	2 X 2 X 3/16 STL	2 X 2 MESH

- NOTES:**
- Dimensions shown do not include fastener heads. Allow 3/8 clearance or 3/4 overall to "A" dimension for wall openings.
 - All parts are coated with a baked epoxy finish.
 - Angle mounting flanges shipped loose and must be ordered separately.
 - Wall damper clearance collars must be used for all motorized dampers and are recommended on automatic exhaust / supply applications.

SHEET METAL MOTOR SIDE GUARDS

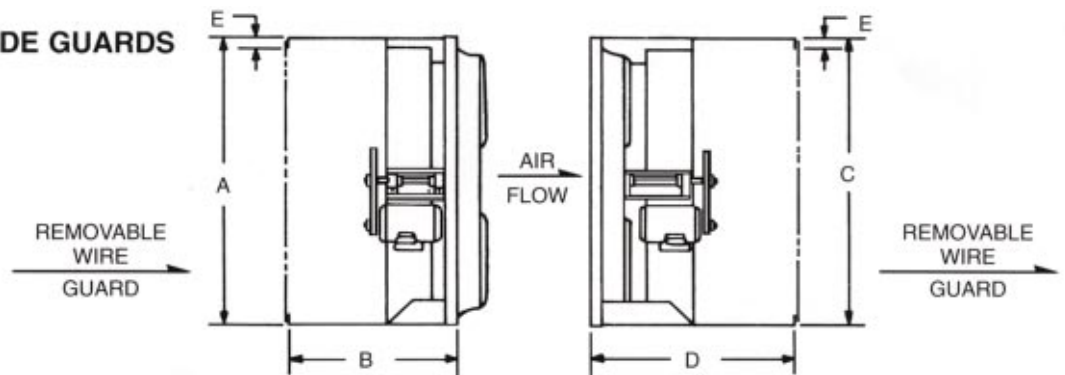

EXHAUST FAN MOTOR SIDE GUARD SUPPLY FAN MOTOR SIDE GUARD

FAN SIZE	EXHAUST		SUPPLY		E	GAUGE ¹	AVG. WT.
	A	B	C	D			
24	30	20	30	28	2	20	42
30	36	20	36	29	2	20	49
36	42	20	42	29	2	20	55
42	48	20	48	35	2	20	75
48	54	20	54	35	2	20	85

- NOTES:**
- All steel construction with a baked on epoxy finish.

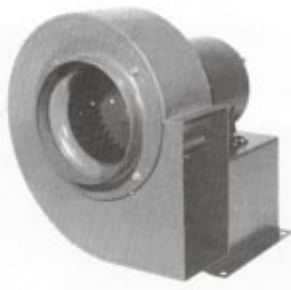

**DIRECT DRIVE
BLOWERS**



**PRESSURE
BLOWERS**



**INDUSTRIAL
FANS**



**DIRECT DRIVE
EXHAUST FANS**



**IN-LINE
CENTRIFUGALS**



**BACKWARD INCLINED
BELT DRIVE BLOWERS**



**CAST IRON
HOUSED BLOWERS**



**BELT DRIVE
PROPELLOR FANS**



**BELT DRIVE
PROPELLOR FANS**



POWERFOIL BLOWERS

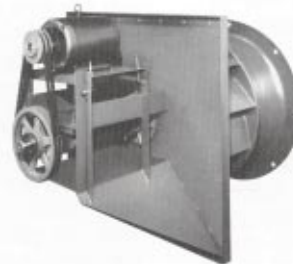

PLUG-PAK FANS



**FORWARD CURVE BELT
DRIVE BLOWERS**

**ISO 9001
REGISTRATION
1385**



PEERLESS ELECTRIC

MADISON MANUFACTURING COMPANY

AFFILIATE OF PEERLESS-WINSMITH, INC.

One Madison Avenue, P.O. Box 187, Hot Springs, NC 28743-0187 • 828/622-7500 • Fax: 828/622-3309 • 1-800/613-4766

RBD-1
MM-17169-2/99-1M
Printed in U.S.A.

